

MIFA[®]

EXPERIENCE PRECISION



Fully finished aluminium
extrusion parts for the
aerospace industry

Aluminium profiles and components for the aerospace industry

In the dynamic world of the aviation industry, every detail matters. Aluminium precision extrusion combines lightweight design with high strength, making it essential for aircraft components. With a wide range of aluminium and magnesium alloys and lightweight profiles with wall thicknesses down to 0.25 mm (0.010 in), we meet aerospace requirements and deliver complex, qualified components - all from a single source.

Precision extrusion

> Dimensional tolerances from ± 0.02 mm (0.0008 in)

Low volume extrusions (> 10 KG/22.046 lb)

> Alternative to machining solid material

Freedom of design

> Design without concessions

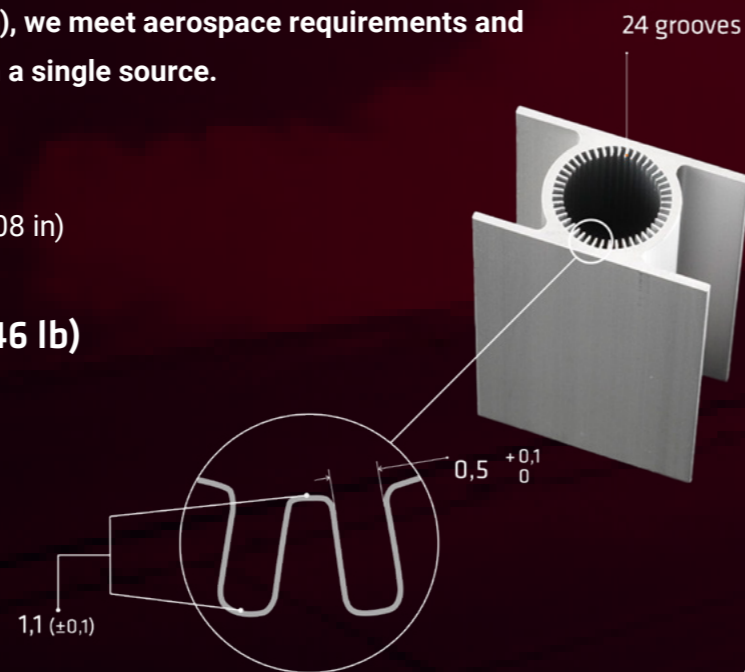

Aluminium precision extrusion: the facts

Mifa specialises in the production of complex aluminium and magnesium profiles with dimensional tolerances starting from ± 0.02 mm (0.0008 in) - an exceptional level of precision, ten times more precise than EN 12020-2 and ASTM B221, which are the standards for aluminium extrusion. Our profiles exceed the standards of straightness, torsion, concentricity, parallelism, surface roughness and fit.

Tolerances	From ± 0.02 mm (0.0008 in)
Minimum order	From 10 kg (22.046 lb) for prototypes
Maximum order	Unlimited
Profile dimensions	From $\varnothing 3$ mm to $\varnothing 180$ mm ($\varnothing 0.118$ in to $\varnothing 7.087$ in) 220 x 60 mm (8.660 x 2.360 in)
Profile weight	From 0.003 kg/m to 10 kg/m (0.002 lb/ft to 6.720 lb/ft)
Surface roughness	From Ra 0.30 (11.811 μ in) in the extrusion direction
Wall thickness	From 0.25 mm (0.010 in)

Why customers choose Mifa

-  Precision extrusion
-  Vertical integration
-  Co-engineering
-  Flexible quantities

Component supplier through vertical integration

Mifa can manage the entire process: development, production, and finishing of aluminium extrusion profiles. We have all the necessary techniques for the entire product process in-house, where sustainable entrepreneurship is applied at every stage.

Vertical integration provides benefits such as:

- > A single point of contact
- > A fully finished precision product
- > Control and knowledge throughout the entire chain
- > Shorter total production time

Machining

Tolerances	From ± 0.01 mm (0.0004 in)
Machine park	<ul style="list-style-type: none"> • More than 30 CNC machines • 3-, 4- and 5-axis operations up to 60,000 RPM • Milling small components to long products • Fully automated production cells • Maximum machine dimensions: X = 6500 mm, Y = 1000 mm, Z = 500 mm (X = 255.906 in, Y = 39.370 in, Z = 19.685 in)
CAD/CAM	<ul style="list-style-type: none"> • Solid Works • Solid Edge • Unigraphics • Catia • Top Solid • Step • IGES

Surface treatment

Standard coatings	Electroplated coatings	Conversion coatings	Custom coatings
<ul style="list-style-type: none"> > Chromating/passivation Surtec 650 > Standard anodising/technical anodising > HART-COAT®/hard anodising > TUFRAM® > GLISSCOAT 2083® > Chemical nickel plating > Wet painting/paint primers/adhesive primers > LECTROFLUOR® 	<ul style="list-style-type: none"> > Silver plating > Gold plating > Tin plating > Hard chrome plating 	<ul style="list-style-type: none"> > Plasma electrolytic oxidation (KEPLA-COAT®) 	<ul style="list-style-type: none"> > CVD/PVD <p>We can also customise surface treatments and coatings on request.</p>

Assembly

Mifa performs numerous processes and techniques in house:

- > Bending
- > Brushing
- > Belt grinding
- > Sealing
- > Soldering
- > Welding
- > Lasering
- > Masking

Alloys for the aerospace industry

Choosing the right aluminium or magnesium alloy for your precision profile is crucial for an optimal end result.

Aluminium	Magnesium	Specials
EN AW 1050	AZ31	6066
EN AW 1070	AZ61	6463
EN AW 3003	Elektron 43	6061 20%SiC
EN AW 6005A		Metal matrix composite
EN AW 6060		Aluminium-scandium alloys
EN AW 6061		
EN AW 6063		
EN AW 6082		
EN AW 7020		
EN AW 7021		
EN AW 7022		
EN AW 7075		

* Other alloys and specials are available on request.

> The 1XXX series

The purest aluminium alloy commercially available, with a purity of over 99%. This alloy is therefore highly resistant to corrosion and has excellent electrical conductivity, but lower strength. Our range includes 1050 and 1070.

> The 6XXX series

These alloys contain silicon and magnesium and are the most versatile. These alloys are also easily heat-treatable, highly formable, weldable, and exceptionally resistant to corrosion. Additionally, they offer a reasonable level of strength.

6061 and 6082 are alloys commonly used in the aerospace industry due to their strength. These alloys are prescribed by the aviation authorities, and are mostly used for aircraft interiors.

> Magnesium alloys

Mifa not only extrudes aluminium, but also magnesium. Magnesium is 35% lighter than aluminium, yet still strong. We extrude three magnesium alloys: E43 - a magnesium alloy permitted in the aerospace industry for making seat, AZ31-F (with 3% aluminium), and AZ61-F (with 6% aluminium).

> The 3XXX series

These aluminium alloys consist mainly of aluminium (Al) and manganese (Mn). Due to the addition of manganese, they are stronger than the 1XXX series, yet still highly formable. We offer the 3003 alloy.

> The 7XXX series

Our standard range includes 7020, 7021, 7022 and 7075 from the 7XXX series. As well as aluminium, the 7020 consists of magnesium and zinc. The 7022 and 7075 also include copper. These alloys can be hardened and are some of the strongest we offer. However, they have reduced malleability and are therefore not suitable for complex products that require high precision. 7075 is a very strong alloy that is commonly used in the aerospace industry for structural parts.

Applications for aerospace

Together with our aerospace customers, we develop profiles and components for:

- > Galleys and trolleys
- > Avionics
- > Lighting
- > Seats
- > Lavatories
- > Overhead compartments
- > Structural components
- > Air management systems

High cosmetic standards

The aerospace industry upholds the highest quality standards. To meet these demanding requirements, Mifa has implemented a comprehensive approach with a strong focus on aesthetics. We specialise in visible profile surfaces and high-quality cosmetic finishes; an essential aspect within the aerospace market.

Cable routing

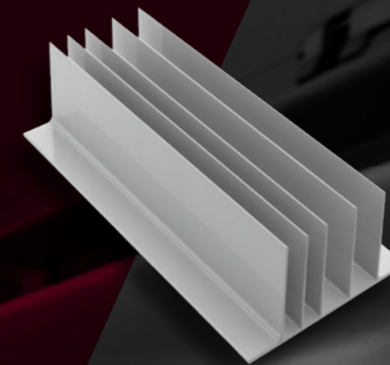

Storage bin

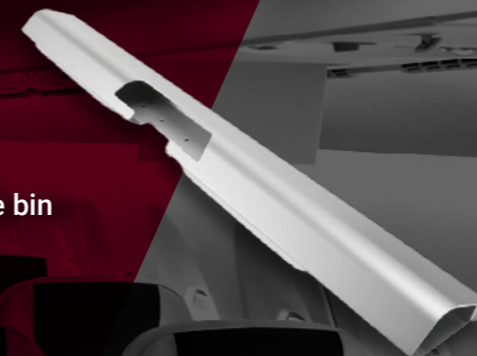

Curtain rails

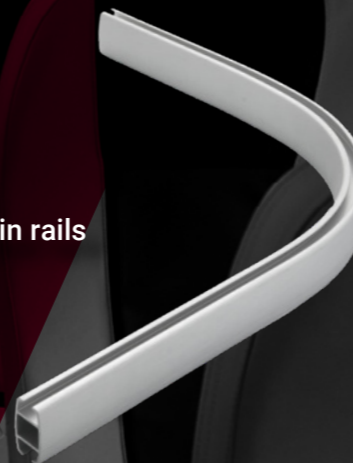

Preferred supplier for space and defense applications

Mifa Aluminium is also a supplier of (finished) components for the space and defense markets. We deliver aluminium and magnesium extrusion profiles for applications such as:

Defense

- > Microwave components (waveguides)
- > Radar systems
- > Launchers
- > Guiding rails
- > Small arms
- > Drones
- > Sensors

Space

- > Satellite frames
- > Heat pipes

Our credentials

Our high quality extrusion profiles are qualified through process control and strict product control. Mifa holds the AS9100 quality certification for the aerospace industry; also known as EN 9100 certification. The aerospace industry has strict requirements for surface quality, material strength and weight of precision profiles. We have the following accreditations:

- > AS9100
- > ISO 9001
- > ISO 14001
- > EcoVadis
- > Joscar
- > Integrity Next



MIFA®

EXPERIENCE PRECISION

Mifa Aluminium BV

Visitor address

Rijnaakkade 6
5928 PT Venlo
The Netherlands

sales@mifa.nl
+31 (0)77 – 389 88 88

Postal address

Postbus 3111
5902 RC Venlo
The Netherlands

www.mifa.eu